

Specifications: D 125-32 Diesel Pile Hammer

Dimensions approx:

Hammer Length:	A1	7800 mm	25FT 7IN
Hammer Length w/starter guides:	A	8865 mm	29FT 1IN
Outer diameter of impact block:	B	910 mm	3FT
Min. Guiding Width:	C	1067 mm	42IN
Width of Hammer:	D	1030 mm	3 FT 4.5IN
Hammer Center to Pump Guard:	F	560 mm	1FT 10IN
Hammer Center to Trip:	G	370 mm	1FT 2.5IN
Hammer Depth:	H	1448 mm	4FT 9IN

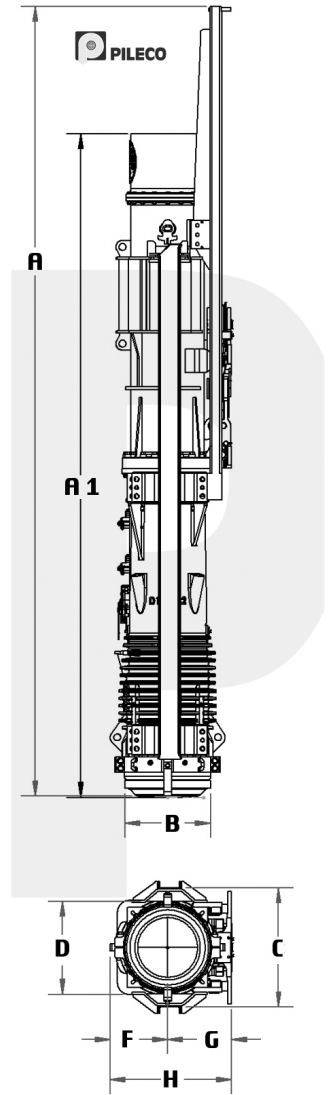

VIEW PARTS MANUAL HERE

Pump Setting 1	251 kNm	184,538 ft.lbs.
Pump Setting 2	314.2 kNm	231,020 ft.lbs.
Pump Setting 3	347.7 kNm	255,660 ft.lbs.
Pump Setting 4	418.2 kNm	307,563 ft.lbs.

Weights approx:

Weight of diesel pile hammer approx.:	30.81 US tons	61,613 lbs
Weight of piston approx.:	12,500 kg	27,557.8 lbs
Impact Block approx.:	3040 kg	6,702 lbs
Tripping device approx.:	870 kg	1,918 lbs
Tool box approx.:	125 kg	275.6 lbs

Energy Per Blow

Max:	418.2 kNm	307,563 ft lbf
Min:	251 kNm	184,538 ft lbf
Number of blows:	36-45 min	

Batter Info

Max. gradient of batter pile driven: 1:2

Consumption

Diesel fuel:	36 L hr.	9.5 gph
Lubrication oil:	3.6 L hr.	1 gph

Volume

Diesel oil tank:	190 L	50.2 gal
Lube tank:	60 L	15.9 gal

